

RECTANGULAR VAV & CAV

PRESSURE INDEPENDENT AIR VOLUME CONTROL TERMINALS

NK | NL TYPE



Composition type designation:

N - L - O - F - O - O - B

N Position 1: **Product group**

N = air volume control terminals

Ordering example:

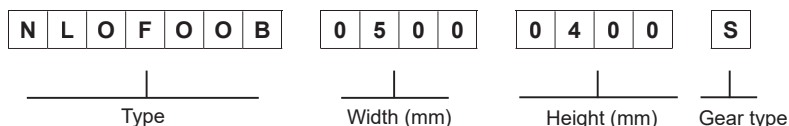

K Position 2: **Function**

O = not applicable
 K = single wall, rectangular VAV terminal, flanged type
 L = double wall, rectangular VAV terminal, flanged type
 1 = non standard, specify separately

O Position 3: **Controls (manufacturer)**

O = controls specified separately

F Position 4: **Outlet and sound attenuator**

O = not applicable
 A = rectangular outlet
 F = rectangular outlet with splitter sound attenuator
 G = honeycomb air straightener
 N = rectangular outlet with plenum for electric reheat coil
 R = rectangular outlet with sound attenuator and with plenum for electric reheat coil
 1 = non standard, specify separately

O Position 5: **Reheat coil**

O = without reheat coil
 E = 1-stage 230VAC/1-phase electric reheat coil
 F = 2-stage 230VAC/1-phase electric reheat coil
 G = 3-stage 230VAC/1-phase electric reheat coil
 H = 1-stage 400VAC/3-phase electric reheat coil
 J = 2-stage 400VAC/3-phase electric reheat coil
 T = 230VAC-1Ph Modulating control (Thyristor)
 V = 400VAC-3Ph Modulating control (Thyristor)
 1 = non standard, specify separately

O Position 6: **Controls (type & function)**

O = not applicable
 R = return/extract application

B Position 7: **Sensor**

O = not applicable
 B = Flo-Cross®, 2 x 12 point averaging and signal amplifying air flow sensor (standard)
 L = damper blades provided with neoprene gasket for shut-off function with Flo-Cross® sensor
 1 = non standard, specify separately

Ordering information:

Standard terminals:

- quantity of terminals
- complete 7 digit code
- terminal size or model
- air volume setting (V_{max} , V_{min} etc)
- control handing (standard right side)
- if applicable, electric reheat coil capacity

Non standard terminals:

- for non standard terminals a full description and/or drawing are requested

Type NK..... / NL.....

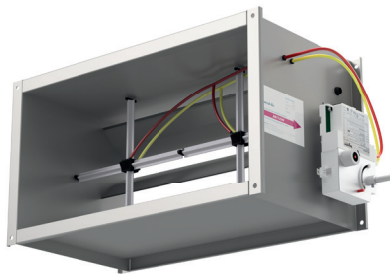

Application

Types NK and NL are rectangular pressure-independent VAV and CAV air volume control terminals. The terminals are designed particularly for systems with larger air volumes and duct sizes and for the accurate measurement and control of air volumes courtesy of the patented airflow sensor type Flo-Cross®. In CAV application, the terminals maintain the required constant airflow independent to the inlet static pressure. Furthermore the VAV terminals can be used for room pressure control.

In VAV application, the terminals control the air volume to the room, depending on the cooling load required thus saving energy consumption in both cooling and heating applications.

Alternatively VAV terminals are ideal to be used for CO2 control. Dependent of the indoor air quality, always the correct amount of fresh air will be supplied to the room. Of course the primary air handling system need to be suitable for this.

The VAV or CAV terminals can be used either for supply or return air applications in new or refurbishment projects.

The terminals do have a single wall (type NK) or double wall (type NL) construction and can optionally be supplied with an additional splitter sound attenuator and a plenum with built-in electric reheat coil.

Features:

- Pressure independent control functions.
- Compact design.
- Volume control range 100% down to 10%.
- Low pressure loss over the terminal.
- Single or double wall construction.
- Factory fitted additional attenuator and/or plenum with built-in electric reheat coil.
- Multi-leaf damper blade; full shut-off optional.
- Low noise production.
- Suitable for large air volumes.
- Suitable for all control functions (VAV, CAV, shut-off, etc.) to maximise system energy savings.
- Flo-Cross® 2 x 12 points averaging and signal amplifying airflow sensor, better than 2,5% accuracy even with irregular duct approach.
- Maintenance free.

Technical information

Casing:

Single or double wall, air-tight construction made of galvanized sheet steel; casing leakage rate to Class II VDI 3803 / DIN 24 194 or NEN-EN 1751 Class C. 30 mm flange connections at the in- and outlet. In case of double wall construction 25 mm insulation material is used, completely enclosed by the double wall construction.

Insulation:

The NL- terminal is supplied with 25 mm thermal and acoustical insulation (30 kg/m³) complying to: NFPA90A and 90B surface burning characteristics, BS476 part 6 and 7 fire propagation, UL 181 class 0 surface spread of flame and UL 94 HF1 flammability. There is no lining in the air stream.

Damper

- Multi-leaf damper, blade coupling system with aluminium gears.
- The blades are made of torsion proof hollow profiles with height of 100mm or 165mm.
- Damper blades are optionally provided with sealing lips for shut-off function. According NEN-EN-1751 class 2. Optional available is sealing according NEN-EN-1751 class 4.
- Damper shaft is made of $\varnothing 12$ mm solid steel and rotating in self lubricating polyamide maintenance free bearings.
- The casing and blades can be optionally supplied in stainless steel type 304 or type 316. Also powder-coated colour according to RAL is optionally available. When a stainless steel or RAL option is selected the Flo-Cross® will maintain standard made out of extruded aluminium with nylon core and feet.
- Recommended damper torques:
For surfaces ≤ 1 m²: 5 Nm.
For surfaces 1 – 2 m²: min. 8 Nm.
For surfaces ≥ 2 m²: min. 15 Nm.

Flo-Cross®:

- Extruded aluminium construction with nylon* core + feet. (* type Bergamid® B70 G30 H BK713-PA6-F30).

Sound attenuator:

- Air-tight construction made out of galvanized sheet steel with a 30 mm flange connection on both sides. The attenuating splitter is fitted inside the casing and is made out of a galvanized sheet steel frame, filled with an attenuating mineral wool which is treated with a protective tissue layer.
- Special type insulation for hospital application on request.

Reheat coil:

- Choice of electric reheat coil 230VAC/1-phase or 400VAC/3-phase. Coils are fitted in plenum made of galvanized sheet steel with 13 mm internal isolation, type Basotect-G® by BASF (technical datasheet available upon request). More detailed technical information can be found in the separate NO documentation. Separately a hot water duct heater is available type NJOGxxx

Controls:

- Suitable for use with pneumatic, analogue electronic or DDC controllers. Controls can be factory fitted, wired and calibrated. Plug&Play. Controls enclosure NEMA-1 (galvanized sheet steel) can be provided optionally.

Delivery format:

- The VAV or CAV terminal will be supplied as a single mounting assembly. Optional ordered distribution plenum, reheat coil and/or controls are factory fitted, wired and calibrated. The on site delivered terminal is ready to be installed and commissioned.
- When terminals are ordered with controls, these will be factory fitted, wired and calibrated upon request. The calibration data will be put on a sticker that is located on the VAV box or VAV controller.
- Controls location and hot water or electric connections are as a standard fitted on the right hand side of the terminal when looking in the direction of the airflow. On request, the terminal can be delivered with connections on the left hand side.
- When terminals are ordered with 'free-issue' controls by others, wiring diagrams and mounting instructions must be provided.

Type NK..... / NL.....

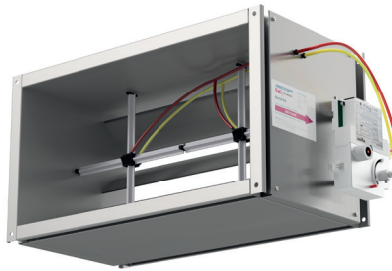

Specify as

Example:

Supply and install, variable air volume terminals, double-wall construction with sound attenuator with rectangular outlet, constructed from galvanized sheet steel. The casing leakage rate shall be classified according to class II, VDI 3803/ DIN 24 194 and the duct-sleeve connections shall be 30 mm flange type. The VAV terminals shall have a multi-leaf opposed blade damper with steel damper shaft rotating in self lubricating Nylon bearings.

A centre averaging airflow sensor with at least 2 x 12 test points and amplified signal air flow sensor, type Flo-Cross® shall control the airflow with an accuracy not less than 2.5 %.

The VAV terminal shall be supplied with an additional sound attenuator made of galvanized sheet steel and internal isolation according to class '0' fire regulation.

The controller shall be I/A Series DDC controller: LON® compatible, type MNL-V2RVx or BACnet® compatible type MNB-V2.

Controls must be factory fitted, wired and calibrated according to the following requirements.

Maximum air volume 1280 l/s
Minimum air volume 512 l/s
Terminal size 400 x 400 mm

Max. pressure loss 38 Pa
Max. discharge sound index < NC35 (@250Pa Δp)
Max. radiated sound index < NC35 (@250Pa Δp)

Ordering example: type – width – height = NLOFOOB – 0400 – 0400-S.

Manufacturer: Barcol-Air, the Netherlands

Installing Instructions:

The Barcol-Air VAV terminals shall be installed using at least two support brackets (DIN-rail or L-profile), with anti-vibration rubber under the terminal. Each of these brackets shall be fixed with two threaded rods to the ceiling slab above.

This installation method:

- 1 Shall prevent the body of the VAV terminal from high mechanical tension, which could damage the construction and performance of the terminal.
- 2 Shall prevent torsion on the VAV terminals, which could cause malfunction of the damper blades.
- 3 Provides some flexibility to the final location of the VAV terminals.
- 4 Use at least 1x diagonal straight duct length before the VAV inlet.
- 5 Additional manual volume control dampers

(VCD's) before the inlet are not required / recommended!!

6. All connections shall be thermally isolated.
7. Pressure sensing tubes of Flo-Cross® airflow sensor shall not be "kinked" or otherwise obstructed by the external duct insulation.

Optional 4 x Mupro fixing hooks can be used (see drawing).

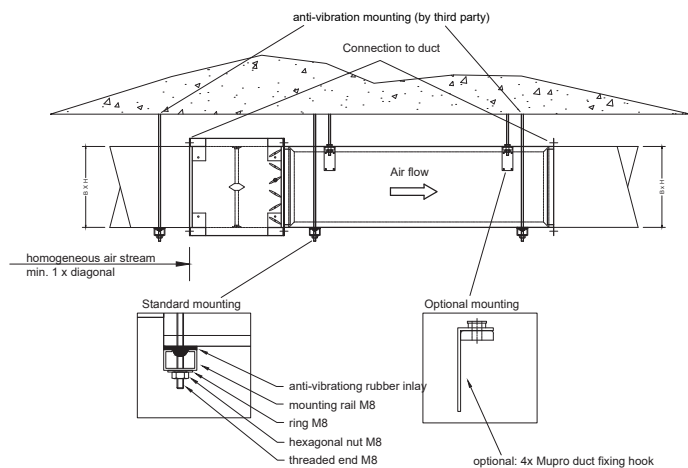

Mounting drawing type NLOFOOB (supply air)

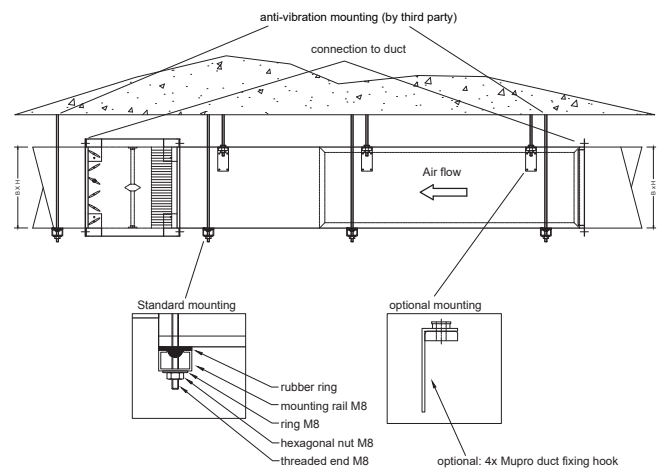

Mounting drawing type NLOFORB (return air)

Type NK.....

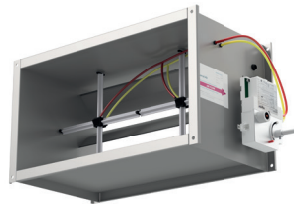

Type NKOA...

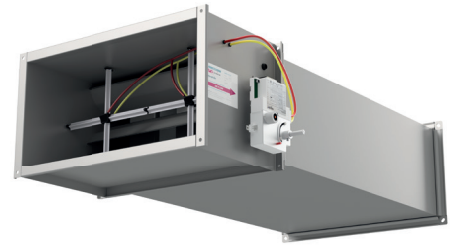

Type NKOF..

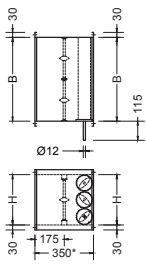

Type NKOA00B

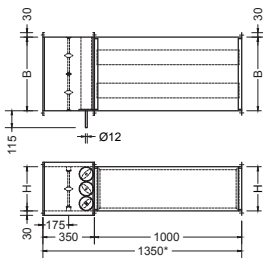

Type NKOF00B

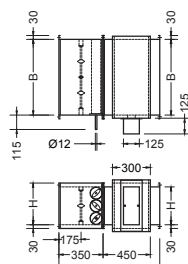

Type NKONO0B

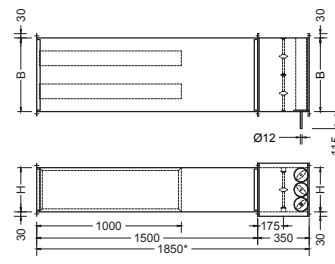

Type NKOFORB (retour)

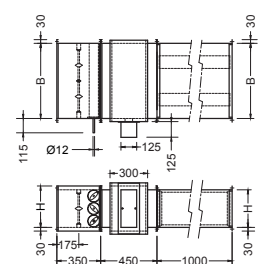

Type NKORO0B

Dimension		Width (W)																		
Height (H)		200	250	300	350	400	450	500	550	600	700	750	800	900	1000	1200	1400	1600	1800	2000
100	*	*	*	*	*	*	*	*	*	*	*	*	*	*	*	*	*	*	*	*
200	*	*	*	*	*	*	*	*	*	*	*	*	*	*	*	*	*	*	*	*
250		*	*	*	*	*	*	*	*	*	*	*	*	*	*	*	*	*	*	*
300			*	*	*	*	*	*	*	*	*	*	*	*	*	*	*	*	*	*
350				*	*	*	*	*	*	*	*	*	*	*	*	*	*	*	*	*
400					*	*	*	*	*	*	*	*	*	*	*	*	*	*	*	*
450						*	*	*	*	*	*	*	*	*	*	*	*	*	*	*
500							*	*	*	*	*	*	*	*	*	*	*	*	*	*
600								*	*	*	*	*	*	*	*	*	*	*	*	*
700									*	*	*	*	*	*	*	*	*	*	*	*
800										*	*	*	*	*	*	*	*	*	*	*
900											*	*	*	*	*	*	*	*	*	*
1000												*	*	*	*	*	*	*	*	*
1100													*	*	*	*	*	*	*	*
1200														*	*	*	*	*	*	*

- Notes:
- All dimensions are in mm.
 - Other dimensions available upon request.
 - * = Installation length.
 - Higher or wider units available upon request.
 - For hot water reheat sections for duct mounting see our separate documentation NJOG/H.

Kv values rectangular VAV terminals (NK/NL/AFS/AHS)

Height		Width (W)																		
(H)		200	250	300	350	400	450	500	550	600	700	750	800	900	1000	1200	1400	1600	1800	2000
100	18	23	26	32	35															
200	35	45	56	63	71	81	91	101	106	126	136	142	162							
250		45	56	63	71	81	91	101	106	126	136	142	162	177						
300			73	87	101	115	123	137	147	175	189	203	220	248	294					
350				87	101	115	123	137	147	175	189	203	220	248	294	386				
400					128	146	165	183	202	238	249	255	292	329	383	386	436			
450						146	165	183	202	238	249	255	292	329	383	386	436	485		
500							211	235	258	291	318	328	376	423	516	580	673	706	801	
600									290	346	373	401	459	515	601	580	673	706	801	
700										408	426	458	542	587	687	794	864	961	1039	
800												506	580	653	760	938	1049	1143	1294	
900													663	747	915	938	1049	1143	1294	
1000														839	1026	1153	1338	1402	1590	
1100															1087	1153	1338	1402	1590	
1200																1136	1367	1582	1660	1884

Flow = Kv x √Δp_{tc}
 Δp_{tc} = Flo-Cross® signal
 Example: If Δp_{tc} = 30 Pa and VAV-size = 500 x 350.
 Flow = 123 x √30 = 674 l/s.

Dimensions

Type NL.....

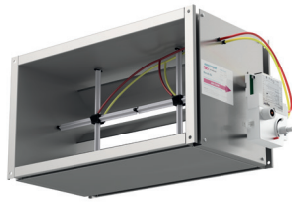

Type NLOA...

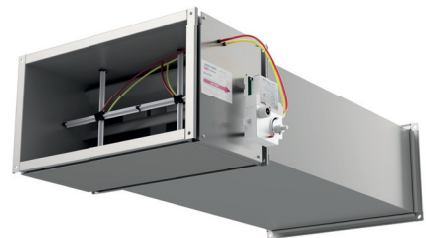

Type NLOF...

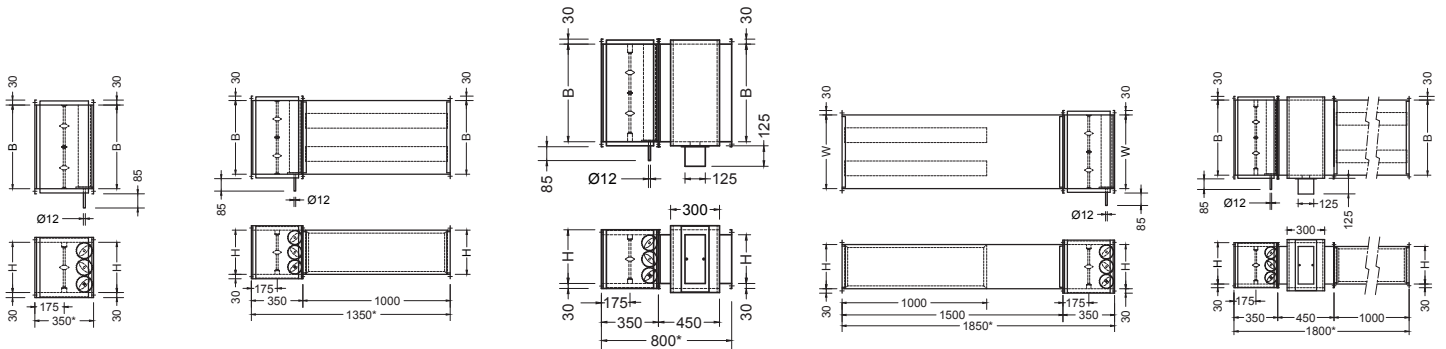

Type NLOAOOB

Type NLOFOOB

Type NLONOOB

Type NLOFORB (retour)

Type NLOROOB

Weight NK terminals (excl. controls, enclosure and attenuator)

Height (H)	Width (W)																		
	200	250	300	350	400	450	500	550	600	700	750	800	900	1000	1200	1400	1600	1800	2000
100	8	9	9	9	9														
200	9	9	10	10	11	11	12	12	13	14	14	14							
250		10	10	11	11	12	12	13	13	15	15	16	17	18					
300			11	11	12	13	13	14	14	16	16	17	18	19	22				
350				12	12	13	14	15	15	17	17	18	20	21	24	27			
400					13	14	15	15	16	18	19	19	21	22	26	29	32		
450						15	15	16	17	19	20	21	22	24	27	31	34	38	
500							16	17	18	20	21	22	24	26	29	33	37	41	44
600										20	22	23	24	26	29	33	42	46	50
700											24	25	27	29	32	37	42	47	52
800													29	32	35	40	46	52	57
900														35	38	44	50	57	63
1000															41	48	55	61	68
1100																51	59	66	74
1200																55	63	71	79

Notes:
1. All dimensions are in mm.

Weight NL terminals (excl. controls, enclosure and attenuator)

Height (H)	Width (W)																		
	200	250	300	350	400	450	500	550	600	700	750	800	900	1000	1200	1400	1600	1800	2000
100	11	11	12	12	13														
200	12	12	13	14	15	15	16	17	18	19	20	21							
250		13	14	15	16	16	17	18	19	20	21	22	24	25					
300			15	16	16	17	18	19	20	22	23	24	25	27	31				
350				16	17	18	19	20	21	23	24	25	27	29	33	37			
400					18	19	20	21	22	24	25	27	29	31	35	39	43		
450						20	21	22	24	26	27	28	30	33	37	42	46	51	
500							22	23	25	27	28	30	32	34	39	44	49	54	58
600									27	30	31	33	35	38	43	49	54	60	65
700										32	34	35	39	42	48	54	60	66	72
800												38	42	45	52	59	65	72	79
900													45	49	56	63	71	78	85
1000														52	60	68	76	84	92
1100															64	73	82	90	99
1200															69	78	87	96	105

Notes:
1. All dimensions are in mm.

Sound data

Type NK OAOB (single wall)
NLOAOB (double wall)

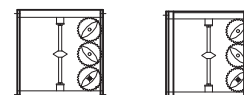

Sound data Δ p = 125 Pa

Model	inlet spigot				min. D p _s	discharge sound									radiated sound single wall						radiated sound double wall																
	velocity		air volume			L _w in dB/Oct. (re 1pW)						Lp values			L _w in dB/Oct. (re 1pW)						Lp values			L _w in dB/Oct. (re 1pW)						Lp values							
	m/s	l/s	CFM	m ³ /h		Pa	125 Hz	250 Hz	500 Hz	1000 Hz	2000 Hz	4000 Hz	dB(A)	NC	NR	125 Hz	250 Hz	500 Hz	1000 Hz	2000 Hz	4000 Hz	dB(A)	NC	NR	125 Hz	250 Hz	500 Hz	1000 Hz	2000 Hz	4000 Hz	dB(A)	NC	NR				
																																		dB			
1000 x 500	2	1000	2118	3600	1	56	57	59	61	61	58	33	26	28	35	34	29	20	20	21	--	--	--	31	30	25	--	--	--	31	30	26	18	18	--	--	--
	4	2000	4235	7200	6	63	62	61	60	58	55	37	30	32	45	46	43	38	35	36	26	--	--	20	41	42	39	34	31	30	22	--	--	--			
	6	3000	6353	10800	13	67	65	64	63	62	60	40	34	36	47	48	45	42	38	40	28	20	23	43	44	41	38	34	34	24	--	--	--				
	8	4000	8471	14400	23	71	68	66	66	64	63	43	39	39	46	47	42	40	38	40	26	--	--	21	42	43	38	36	34	34	22	--	--	--			
	10	5000	10588	18000	35	73	70	68	67	66	65	45	42	41	48	46	41	40	40	41	26	--	--	21	44	42	37	36	36	35	22	--	--	--			
1200 x 600	2	1440	3049	5184	1	58	59	61	63	62	58	34	27	29	35	34	30	22	22	22	--	--	--	31	30	26	18	18	--	--	--	--	--	--			
	4	2880	6099	10368	6	64	63	62	61	59	55	38	32	33	45	46	44	40	37	37	26	--	--	20	41	42	40	36	33	31	22	--	--	--			
	6	4320	9148	15552	13	68	66	65	64	63	60	41	35	37	47	47	45	43	40	41	28	20	23	43	44	41	39	36	35	24	--	--	--				
	8	5760	12198	20736	23	71	69	68	67	66	64	44	39	40	46	48	43	41	39	41	26	--	--	21	42	43	39	37	35	35	22	--	--	--			
	10	7200	15247	25920	35	74	71	70	69	68	66	46	43	43	48	46	42	41	42	43	27	--	--	21	44	42	38	37	38	37	23	--	--	--			
1400 x 700	2	1960	4151	7056	1	59	61	63	64	63	58	36	29	31	35	34	31	23	23	24	--	--	--	31	30	27	19	19	18	--	--	--	--				
	4	3920	8301	14112	6	65	64	63	62	59	55	38	33	35	45	46	44	41	38	39	26	--	--	20	41	42	40	37	34	33	22	--	--	--			
	6	5880	12452	21168	13	69	67	67	66	64	61	42	37	38	47	48	46	45	41	43	29	20	23	43	44	42	41	37	37	24	--	--	--				
	8	7840	16602	28224	23	72	70	69	68	67	64	45	41	41	46	47	43	43	41	42	27	--	--	21	42	43	39	39	37	36	23	--	--	--			
	10	9800	20753	35280	35	75	72	71	70	69	67	47	45	44	48	46	42	43	43	44	27	--	--	21	44	42	38	39	39	38	23	--	--	--			
1600 x 800	2	2560	5421	9216	1	61	63	65	65	63	58	38	32	33	35	34	31	24	24	25	--	--	--	31	30	27	20	20	19	--	--	--	--				
	4	5120	10842	18432	6	66	65	64	63	60	56	39	34	36	45	46	45	42	39	40	27	--	--	21	41	42	41	38	35	34	23	--	--	--			
	6	7680	16264	27648	13	70	68	68	66	65	61	43	38	39	47	48	46	46	43	44	29	20	23	43	44	42	42	39	38	25	--	--	--				
	8	10240	21685	36864	23	73	71	70	69	67	65	46	42	42	46	47	44	44	42	44	27	--	--	21	42	43	40	40	38	38	23	--	--	--			
	10	12800	27106	46080	35	75	73	72	71	70	67	48	45	44	48	46	43	44	44	45	28	20	22	44	42	39	40	40	39	24	--	--	--				
1800 x 900	2	3240	6861	11664	1	62	64	66	66	64	57	39	33	35	35	34	31	25	25	26	--	--	--	31	30	27	21	21	20	--	--	--	--				
	4	6480	13722	23328	6	67	66	65	63	60	56	40	35	37	45	46	45	43	40	41	27	--	--	21	41	42	41	39	36	35	23	--	--	--			
	6	9720	20584	34992	13	71	69	68	67	65	62	44	39	40	47	48	47	47	44	45	29	20	23	43	44	43	43	40	39	25	--	--	--				
	8	12960	27445	46656	23	73	72	71	70	68	65	47	42	43	46	47	44	45	43	45	28	--	--	21	42	43	40	41	39	39	24	--	--	--			
	10	16200	34306	58320	35	76	74	73	72	70	68	49	46	45	48	46	43	45	45	46	28	21	23	44	42	39	41	41	40	24	--	--	--				
2000 x 1200	2	4800	10165	17280	1	64	66	68	67	64	56	40	35	37	35	34	32	27	27	27	--	--	--	31	30	28	23	23	21	--	--	--	--				
	4	9600	20329	34560	6	68	67	66	64	61	56	41	36	38	45	46	46	45	42	43	28	--	--	22	41	42	42	41	38	37	24	--	--	--			
	6	14400	30494	51840	13	72	71	70	68	66	62	45	41	42	47	48	47	48	45	47	30	22	24	43	44	43	44	41	41	26	--	--	20				
	8	19200	40659	69120	23	74	73	72	71	69	66	48	43	44	46	47	45	47	44	46	29	20	23	42	43	41	43	40	40	24	--	--	--				
	10	24000	50824	86400	35	77	75	74	73	71	69	50	47	46	48	46	44	47	47	48	29	23	25	44	42	40	43	43	42	25	--	--	21				

1. Sound data is determined in a reverberation room at an independent sound laboratory, according to ISO 3741 and ISO 5135 standards.
2. L_w in dB/Oct. (re 1pW) are sound power levels for discharge sound and case radiated sound. Figures less than 17 dB are indicated by "--".
3. The discharge sound pressure levels are determined with the assumptions as referred to in table 1 for downstream ductwork including a diffuser with insulated plenum box.
4. The radiated sound pressure levels are determined with the assumptions as referred to in table 1 for ceiling plenum and suspended ceiling absorption.
5. Lp values are including a room absorption of 10 dB/Oct.
6. dB(A), NC and NR index figures are sound pressure levels. Figures less than 20 are indicated by "--".
7. Δps is static pressure drop across VAV air volume control terminal with damper fully open.
8. Sound data indicated by "X" are not provided as minimum required static pressure drop is more than the given pressure drop.
9. For non standard applications and/or selections, please contact our technical staff.

Table 1: Assumptions for additional attenuation

dB \ Hz	125	250	500	1000	2000	4000
Discharge (dB)	5	10	20	30	30	25
Radiated (dB)	2	5	10	15	15	20

Type NK O A O O B (single wall)
 NL O A O O B (double wall)

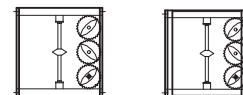

Sound data $\Delta p = 250 \text{ Pa}$

Model	inlaat zijde				min. D_{ps}	discharged sound									radiated sound single wall									radiated sound double wall										
	velocity		air volume			L_w in dB/Oct. (re 1pW)						Lp values			L_w in dB/Oct. (re 1pW)						Lp values			L_w in dB/Oct. (re 1pW)						Lp values				
						125 Hz	250 Hz	500 Hz	1000 Hz	2000 Hz	4000 Hz	dB(A)	NC	NR	125 Hz	250 Hz	500 Hz	1000 Hz	2000 Hz	4000 Hz	dB(A)	NC	NR	125 Hz	250 Hz	500 Hz	1000 Hz	2000 Hz	4000 Hz	dB(A)	NC	NR		
	dB						dB								dB																			
200 x 100	2	40	85	144	1	56	50	48	49	51	53	28	21	24	28	27	22	-	-	-	-	-	-	24	23	18	-	-	-	-	-	-	-	
	4	80	169	288	6	65	60	56	55	54	53	36	31	32	38	39	35	27	24	24	-	-	-	34	35	31	23	20	18	-	-	-	-	
	6	120	254	432	13	72	65	61	58	57	56	42	41	40	45	47	44	39	33	34	26	-	22	41	43	40	35	29	28	22	-	-	-	-
	8	160	339	576	23	78	70	64	61	59	58	48	49	47	46	48	45	41	35	36	27	20	23	42	44	41	37	31	30	23	-	-	-	-
350 x 200	2	140	296	504	1	56	54	54	56	58	59	31	27	29	33	33	27	-	-	-	-	-	-	29	29	23	-	-	-	-	-	-		
	4	280	593	1008	6	66	62	60	59	58	57	38	33	33	44	45	40	33	29	30	24	-	-	40	41	36	29	25	24	20	-	-	-	
	6	420	889	1512	13	71	67	64	63	62	61	43	39	39	50	53	50	44	39	39	32	25	28	46	49	46	40	35	33	28	21	23	-	
	8	560	1186	2016	23	76	70	67	65	64	63	47	46	45	51	54	50	46	41	42	33	27	29	47	50	46	42	37	36	29	22	24	-	
400 x 400	2	320	678	1152	1	58	58	59	61	63	62	34	30	32	37	36	31	19	18	18	-	-	-	33	32	27	-	-	-	-	-	-		
	4	640	1355	2304	6	67	64	63	62	61	59	39	34	35	47	48	44	36	33	33	27	20	23	43	44	40	32	29	27	23	-	-		
	6	960	2033	3456	13	72	68	67	66	65	63	44	41	40	54	56	53	48	42	43	35	30	31	50	52	49	44	38	37	31	25	27	-	
	8	1280	2711	4608	23	76	72	69	68	67	66	48	46	45	55	57	54	50	44	45	36	31	33	51	53	50	46	40	39	32	26	28	-	
500 x 400	2	400	847	1440	1	59	59	60	63	64	63	35	31	33	37	36	31	20	19	19	-	-	-	33	32	27	-	-	-	-	-	-		
	4	800	1694	2880	6	67	65	64	63	62	60	40	34	36	47	48	44	37	34	34	27	20	23	43	44	40	33	30	28	23	-	-		
	6	1200	2541	4320	13	72	69	67	66	65	64	44	41	40	54	56	54	49	43	44	36	30	31	50	52	50	45	39	38	32	25	27	-	
	8	1600	3388	5760	23	76	72	70	69	68	67	48	46	45	55	57	54	51	45	46	37	31	33	51	53	50	47	41	40	33	26	28	-	
600 x 400	2	480	1016	1728	1	59	60	62	64	65	63	36	31	33	37	36	32	21	20	20	-	-	-	33	32	28	-	-	-	-	-	-		
	4	960	2033	3456	6	68	66	65	64	62	60	41	35	37	47	48	45	38	34	35	27	20	23	43	44	41	34	30	29	23	-	-		
	6	1440	3049	5184	13	72	70	68	67	66	64	45	41	41	54	56	54	50	44	45	36	30	31	50	52	50	46	40	39	32	25	27	-	
	8	1920	4066	6912	23	76	73	71	69	69	67	48	46	45	55	57	54	52	46	47	37	31	33	51	53	50	48	42	41	33	26	28	-	
800 x 400	2	640	1355	2304	1	60	61	63	65	66	64	37	32	34	37	36	32	22	21	21	-	-	-	33	32	28	18	17	-	-	-	-		
	4	1280	2711	4608	6	68	67	66	65	63	61	42	36	38	47	48	45	39	36	36	28	20	23	43	44	41	35	32	30	24	-	-		
	6	1920	4066	6912	13	73	70	69	68	67	65	45	42	41	54	56	54	51	45	46	36	30	31	50	52	50	47	41	40	32	25	27	-	
	8	2560	5421	9216	23	77	73	72	70	70	68	49	47	46	55	57	55	53	47	48	37	31	33	51	53	51	49	43	42	33	26	28	-	
900 x 450	2	810	1715	2916	1	61	62	65	66	67	64	38	32	34	37	36	32	23	22	22	-	-	-	33	32	28	19	18	-	-	-	-		
	4	1620	3431	5832	6	69	68	67	66	64	61	43	38	39	47	48	46	40	37	37	28	20	23	43	44	42	36	33	31	24	-	-		
	6	2430	5146	8748	13	73	71	70	69	68	66	46	42	42	54	56	55	52	46	47	36	30	31	50	52	51	48	42	41	32	25	27	-	
	8	3240	6861	11664	23	77	74	72	71	70	69	49	47	46	55	57	55	54	48	49	37	31	33	51	53	51	50	44	43	33	26	28	-	

- Sound data is determined in a reverberation room at an independent sound laboratory, according to ISO 3741 and ISO 5135 standards.
- L_w in dB/Oct. (re 1pW) are sound power levels for discharge sound and case radiated sound. Figures less than 17 dB are indicated by “-”.
- The discharge sound pressure levels are determined with the assumptions as referred to in table 1 for downstream ductwork including a diffuser with insulated plenum box.
- The radiated sound pressure levels are determined with the assumptions as referred to in table 1 for ceiling plenum and suspended ceiling absorption.
- L_p values are including a room absorption of 10 dB/Oct.

- dB(A), NC and NR index figures are sound pressure levels. Figures less than 20 are indicated by “-”.
- Δp_s is static pressure drop across VAV air volume control terminal with damper fully open.
- Sound data indicated by “X” are not provided as minimum required static pressure drop is more than the given pressure drop.
- For non standard applications and/or selections, please contact our technical staff.

Table 1: Assumptions for additional attenuation

dB \ Hz	125	250	500	1000	2000	4000
Discharge (dB)	5	10	20	30	30	25
Radiated (dB)	2	5	10	15	15	20

Type NK O A O O B (single wall)
 N L O A O O B (double wall)

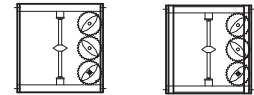

Sound data $\Delta p = 250 \text{ Pa}$

Model	inlet spigot				min. $D p_s$ Pa	discharge sound									radiated sound single wall									radiated sound double wall								
	velocity		air volume			L_w in dB/Oct. (re 1pW)						Lp values			L_w in dB/Oct. (re 1pW)						Lp values			L_w in dB/Oct. (re 1pW)						Lp values		
						125 Hz	250 Hz	500 Hz	1000 Hz	2000 Hz	4000 Hz	dB(A)	NC	NR	125 Hz	250 Hz	500 Hz	1000 Hz	2000 Hz	4000 Hz	dB(A)	NC	NR	125 Hz	250 Hz	500 Hz	1000 Hz	2000 Hz	4000 Hz	dB(A)	NC	NR
	m/s	l/s	CFM	m ³ /h		dB									dB									dB								
1000 x 500	2	1000	2118	3600	1	62	64	66	68	67	64	39	33	35	37	36	33	24	23	23	--	--	--	33	32	29	20	19	17	--	--	--
	4	2000	4235	7200	6	70	68	67	66	64	61	43	38	39	47	48	46	41	38	38	28	20	23	43	44	42	37	34	32	24	--	--
	6	3000	6353	10800	13	74	72	71	70	68	66	47	43	43	54	56	55	53	47	48	37	30	31	50	52	51	49	43	42	33	25	27
	8	4000	8471	14400	23	77	75	73	72	71	69	50	47	46	55	57	56	55	49	50	38	31	33	51	53	52	51	45	44	34	26	28
	10	5000	10588	18000	35	80	77	75	74	73	72	52	51	49	54	56	54	54	48	50	36	29	31	50	52	50	50	44	44	32	25	27
1200 x 600	2	1440	3049	5184	1	64	66	68	69	69	65	41	35	37	37	36	33	25	25	25	--	--	--	33	32	29	21	21	19	--	--	--
	4	2880	6099	10368	6	71	70	69	67	65	62	44	40	41	47	48	47	43	39	40	28	20	23	43	44	43	39	35	34	24	--	--
	6	4320	9148	15552	13	75	73	72	71	70	67	48	45	44	54	56	56	55	49	50	37	30	32	50	52	52	51	45	44	33	26	28
	8	5760	12198	20736	23	78	76	74	73	72	70	51	49	47	55	57	56	56	51	52	38	31	33	51	53	52	52	47	46	34	26	28
	10	7200	15247	25920	35	81	78	76	75	74	73	53	52	51	54	56	54	55	50	52	37	29	31	50	52	50	51	46	46	33	25	27
1400 x 700	2	1960	4151	7056	1	66	68	70	71	69	65	43	38	39	37	36	34	27	26	26	--	--	--	33	32	30	23	22	20	--	--	--
	4	3920	8301	14112	6	72	71	70	68	66	62	45	41	42	47	48	47	44	41	41	29	21	23	43	44	43	40	37	35	25	--	--
	6	5880	12452	21168	13	76	74	73	72	70	67	49	46	45	54	56	56	56	50	51	38	31	32	50	52	52	52	46	45	34	26	28
	8	7840	16602	28224	23	79	77	76	75	73	71	52	50	48	55	57	57	58	52	53	39	31	34	51	53	53	54	48	47	35	27	30
	10	9800	20753	35280	35	81	79	77	76	75	73	54	52	51	54	56	55	56	51	53	38	30	32	50	52	51	52	47	47	34	26	28
1600 x 800	2	2560	5421	9216	1	67	69	71	72	70	64	44	39	40	37	36	34	28	27	27	--	--	--	33	32	30	24	23	21	--	--	--
	4	5120	10842	18432	6	73	72	71	69	67	62	46	42	43	47	48	48	45	42	42	29	21	24	43	44	44	41	38	36	25	--	--
	6	7680	16264	27648	13	76	75	74	73	71	68	50	46	46	54	56	57	57	51	52	38	31	33	50	52	53	53	47	46	34	27	29
	8	10240	21685	36864	23	79	78	76	76	74	71	52	50	50	55	57	57	59	53	54	40	32	35	51	53	53	55	49	48	36	28	31
	10	12800	27106	46080	35	82	80	78	77	76	74	55	54	52	54	56	55	58	52	54	38	31	34	50	52	51	54	48	48	34	27	30
1800 x 900	2	3240	6861	11664	1	69	71	73	73	70	64	46	41	42	37	36	35	29	28	28	--	--	--	33	32	31	25	24	22	--	--	--
	4	6480	13722	23328	6	74	73	72	70	67	62	47	43	44	47	48	48	46	43	43	30	22	24	43	44	44	42	39	37	26	--	20
	6	9720	20584	34992	13	77	76	75	74	72	68	51	47	47	54	56	57	58	52	53	39	32	34	50	52	53	54	48	47	35	28	30
	8	12960	27445	46656	23	80	78	77	76	75	72	53	51	50	55	57	58	60	54	55	40	33	36	51	53	54	56	50	49	36	29	32
	10	16200	34306	58320	35	82	80	79	78	77	75	55	54	52	54	56	56	59	54	55	39	32	35	50	52	52	55	50	49	35	28	31
2000 x 1200	2	4800	10165	17280	1	71	73	74	74	71	63	47	43	44	37	36	36	31	30	30	--	--	--	33	32	32	27	26	24	--	--	--
	4	9600	20329	34560	6	75	74	73	71	68	62	48	45	45	47	48	49	48	44	45	30	22	25	43	44	45	44	40	39	26	--	21
	6	14400	30494	51840	13	78	77	76	75	73	68	52	49	48	54	56	58	60	54	55	40	33	36	50	52	54	56	50	49	36	29	32
	8	19200	40659	69120	23	81	80	79	78	76	72	55	52	52	55	57	58	62	56	57	41	35	38	51	53	54	58	52	51	37	31	34
	10	24000	50824	86400	35	83	82	81	80	78	75	57	55	54	54	56	56	60	55	57	40	34	36	50	52	52	56	51	51	36	30	32

- Sound data is determined in a reverberation room at an independent sound laboratory, according to ISO 3741 and ISO 5135 standards.
- L_w in dB/Oct. (re 1pW) are sound power levels for discharge sound and case radiated sound. Figures less than 17 dB are indicated by "--".
- The discharge sound pressure levels are determined with the assumptions as referred to in table 1 for downstream ductwork including a diffuser with insulated plenum box.
- The radiated sound pressure levels are determined with the assumptions as referred to in table 1 for ceiling plenum and suspended ceiling absorption.
- Lp values are including a room absorption of 10 dB/Oct.

- dB(A), NC and NR index figures are sound pressure levels. Figures less than 20 are indicated by "--".
- Δp_s is static pressure drop across VAV air volume control terminal with damper fully open.
- Sound data indicated by "X" are not provided as minimum required static pressure drop is more than the given pressure drop.
- For non standard applications and/or selections, please contact our technical staff.

Table 1: Assumptions for additional attenuation

dB \ Hz	125	250	500	1000	2000	4000
Discharge (dB)	5	10	20	30	30	25
Radiated (dB)	2	5	10	15	15	20

Type **NKOFOOB** NKOFORB (single wall)
NLOFOOB NLOFORB (double wall)

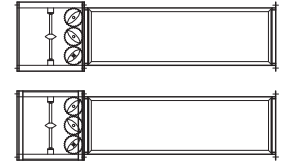

Sound data $\Delta p = 125 \text{ Pa}$

Model	inlet spigot				min. D p _s	discharge sound						radiated sound single wall						radiated sound double wall															
	velocity		air volume			L _w in dB/Oct. (re 1pW)						Lp values			L _w in dB/Oct. (re 1pW)						Lp values			L _w in dB/Oct. (re 1pW)						Lp values			
	m/s	l/s	CFM	m³/h		Pa	125 Hz	250 Hz	500 Hz	1000 Hz	2000 Hz	4000 Hz	dB(A)	NC	NR	125 Hz	250 Hz	500 Hz	1000 Hz	2000 Hz	4000 Hz	dB(A)	NC	NR	125 Hz	250 Hz	500 Hz	1000 Hz	2000 Hz	4000 Hz	dB(A)	NC	NR
							dB									dB									dB								
350 x 200	2	140	296	504	9	41	35	31	25	27	33	12	--	--	31	30	24	-	-	-	--	--	--	27	26	20	-	-	-	--	--	--	
	4	280	593	1008	39	51	43	39	32	29	31	21	--	--	42	42	38	30	27	27	21	--	--	38	38	34	26	23	21	--	--	--	
	6	420	889	1512	78	58	49	43	38	34	36	28	22	24	43	44	39	33	30	31	23	--	--	39	40	35	29	26	25	--	--	--	
	8	560	1186	2016	142	X	X	X	X	X	X	X	X	X	X	X	X	X	X	X	X	X	X	X	X	X	X	X	X	X	X	X	X
	10	700	1482	2520	225	X	X	X	X	X	X	X	X	X	X	X	X	X	X	X	X	X	X	X	X	X	X	X	X	X	X	X	X
400 x 400	2	320	678	1152	5	44	41	38	34	35	41	17	--	--	35	34	27	-	-	-	--	--	--	31	30	23	-	-	-	--	--	--	
	4	640	1355	2304	22	53	49	42	36	34	37	24	--	--	45	46	41	33	30	31	25	--	--	20	41	42	37	29	26	25	21	--	--
	6	960	2033	3456	48	59	53	47	40	39	42	29	23	25	47	48	43	37	34	35	27	20	23	43	44	39	33	30	29	23	--	--	
	8	1280	2711	4608	85	63	56	51	45	42	44	34	29	30	46	47	40	35	33	35	25	--	--	21	42	43	36	31	29	29	21	--	--
	10	1600	3388	5760	132	X	X	X	X	X	X	X	X	X	X	X	X	X	X	X	X	X	X	X	X	X	X	X	X	X	X	X	X
500 x 400	2	400	847	1440	3	47	47	44	40	43	47	21	--	--	35	34	28	-	-	-	--	--	--	31	30	24	-	-	-	--	--	--	
	4	800	1694	2880	12	56	54	47	40	41	44	28	20	23	45	46	42	34	31	32	25	--	--	20	41	42	38	30	27	26	21	--	--
	6	1200	2541	4320	25	61	57	51	44	45	48	32	26	28	47	48	43	38	34	36	27	20	23	43	44	39	34	30	30	23	--	--	
	8	1600	3388	5760	46	64	61	54	47	48	51	36	31	32	46	47	40	36	34	36	25	--	--	21	42	43	36	32	30	30	21	--	--
	10	2000	4235	7200	70	69	63	56	50	50	53	39	36	36	48	46	40	36	36	37	26	--	--	21	44	42	36	32	32	31	22	--	--
600 x 400	2	480	1016	1728	5	46	43	41	36	37	42	19	--	--	35	34	28	-	-	-	--	--	--	31	30	24	-	-	-	--	--	--	
	4	960	2033	3456	22	54	50	44	37	36	38	25	--	20	45	46	42	35	32	33	25	--	--	20	41	42	38	31	28	27	21	--	--
	6	1440	3049	5184	48	60	54	48	42	40	43	31	25	26	47	48	43	38	35	37	27	20	23	43	44	39	34	31	31	23	--	--	
	8	1920	4066	6912	85	65	58	52	46	44	46	35	31	32	46	47	41	37	34	36	25	--	--	21	42	43	37	33	30	30	21	--	--
	10	2400	5082	8640	132	X	X	X	X	X	X	X	X	X	X	X	X	X	X	X	X	X	X	X	X	X	X	X	X	X	X	X	X
800 x 400	2	640	1355	2304	5	47	45	43	38	38	42	20	--	--	35	34	29	18	18	19	--	--	--	31	30	25	-	-	-	--	--	--	
	4	1280	2711	4608	22	55	51	45	38	37	39	26	--	21	45	46	42	36	33	34	25	--	--	20	41	42	38	32	29	28	21	--	--
	6	1920	4066	6912	48	60	55	49	43	41	44	31	25	27	47	48	44	40	37	38	27	20	23	43	44	40	36	33	32	23	--	--	
	8	2560	5421	9216	85	65	59	54	48	45	47	36	31	32	46	47	41	38	36	38	26	--	--	21	42	43	37	34	32	32	22	--	--
	10	3200	6776	11520	132	X	X	X	X	X	X	X	X	X	X	X	X	X	X	X	X	X	X	X	X	X	X	X	X	X	X	X	X
900 x 450	2	810	1715	2916	4	49	49	46	42	43	46	23	--	--	35	34	29	19	19	20	--	--	--	31	30	25	-	-	-	--	--	--	
	4	1620	3431	5832	17	56	54	48	41	41	42	28	21	24	45	46	43	37	34	35	25	--	--	20	41	42	39	33	30	29	21	--	--
	6	2430	5146	8748	34	62	58	52	45	45	47	33	27	28	47	48	44	41	38	39	27	20	23	43	44	40	37	34	33	23	--	--	
	8	3240	6861	11664	62	66	60	55	49	48	50	36	32	33	46	47	42	39	37	39	26	--	--	21	42	43	38	35	33	33	22	--	--
	10	4050	8576	14580	92	69	64	58	52	51	53	40	37	37	48	46	41	39	39	40	26	--	--	21	44	42	37	35	35	34	22	--	--

- Sound data is determined in a reverberation room at an independent sound laboratory, according to ISO 3741 and ISO 5135 standards.
- L_w in dB/Oct. (re 1pW) are sound power levels for discharge sound and case radiated sound. Figures less than 17 dB are indicated by "--".
- The discharge sound pressure levels are determined with the assumptions as referred to in table 1 for downstream ductwork including a diffuser with insulated plenum box.
- The radiated sound pressure levels are determined with the assumptions as referred to in table 1 for ceiling plenum and suspended ceiling absorption.
- Lp values are including a room absorption of 10 dB/Oct.
- dB(A), NC and NR index figures are sound pressure levels. Figures less than 20 are indicated by "--".
- Δp_s is static pressure drop across VAV air volume control terminal with damper fully open.
- Sound data indicated by "X" are not provided as minimum required static pressure drop is more than the given pressure drop.
- For non standard applications and/or selections, please contact our technical staff.

Table 1: Assumptions for additional attenuation

dB \ Hz	125	250	500	1000	2000	4000
Discharge (dB)	5	10	20	30	30	25
Radiated (dB)	2	5	10	15	15	20

Sound data

Type NKOFOOB NKOFORB (single wall)
 NLOFOOB NLOFORB (double wall)

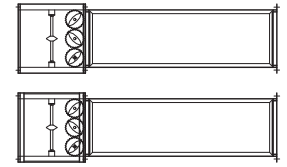

Sound data $\Delta p = 125 \text{ Pa}$

Model	inlet spigot				min. D p _s Pa	discharge sound						radiated sound single wall						radiated sound double wall														
	velocity		air volume			L _w in dB/Oct. (re 1pW)						Lp values			L _w in dB/Oct. (re 1pW)						Lp values											
	m/s	l/s	CFM	m³/h		125 Hz	250 Hz	500 Hz	1000 Hz	2000 Hz	4000 Hz	dB(A)	NC	NR	125 Hz	250 Hz	500 Hz	1000 Hz	2000 Hz	4000 Hz	dB(A)	NC	NR	125 Hz	250 Hz	500 Hz	1000 Hz	2000 Hz	4000 Hz	dB(A)	NC	NR
						dB									dB									dB								
1000 x 500	2	1000	2118	3600	5	49	47	45	40	40	43	22	--	--	35	34	29	20	20	21	--	--	--	31	30	25	--	--	--	--	--	--
	4	2000	4235	7200	22	56	53	47	40	38	40	28	20	22	45	46	43	38	35	36	26	--	20	41	42	39	34	31	30	22	--	--
	6	3000	6353	10800	48	61	56	51	45	43	45	32	27	28	47	48	45	42	38	40	28	20	23	43	44	41	38	34	34	24	--	--
	8	4000	8471	14400	85	66	60	55	50	47	49	37	33	34	46	47	42	40	38	40	26	--	21	42	43	38	36	34	34	22	--	--
	10	5000	10588	18000	132	X	X	X	X	X	X	X	X	X	X	X	X	X	X	X	X	X	X	X	X	X	X	X	X	X	X	X
1200 x 600	2	1440	3049	5184	5	52	47	48	50	54	51	25	--	21	35	34	30	22	22	22	--	--	--	31	30	26	18	18	--	--	--	--
	4	2880	6099	10368	22	59	51	49	48	51	48	29	23	25	45	46	44	40	37	37	26	--	20	41	42	40	36	33	31	22	--	--
	6	4320	9148	15552	49	63	55	53	51	55	53	34	29	30	46	47	45	43	40	41	28	20	23	43	44	41	39	36	35	24	--	--
	8	5760	12198	20736	87	68	60	57	55	58	57	38	35	35	46	47	43	41	39	41	26	--	21	42	43	39	37	35	35	22	--	--
	10	7200	15247	25920	134	X	X	X	X	X	X	X	X	X	X	X	X	X	X	X	X	X	X	X	X	X	X	X	X	X	X	X
1400 x 700	2	1960	4151	7056	3	55	52	55	56	60	54	29	21	24	35	34	31	23	23	24	--	--	--	31	30	27	19	19	18	--	--	--
	4	3920	8301	14112	11	61	56	55	54	56	51	32	26	27	45	46	44	41	38	39	26	--	20	41	42	40	37	34	33	22	--	--
	6	5880	12452	21168	26	65	59	59	59	61	57	37	32	33	47	48	46	45	41	43	29	20	23	43	44	42	41	37	37	24	--	--
	8	7840	16602	28224	44	69	62	61	61	64	60	40	36	37	46	47	43	43	41	42	27	--	21	42	43	39	39	37	36	23	--	--
	10	9800	20753	35280	69	73	65	64	63	66	63	43	41	41	48	46	42	43	43	44	27	--	21	44	42	38	39	39	38	23	--	--
1600 x 800	2	2560	5421	9216	5	55	51	52	52	55	51	28	--	21	35	34	31	24	24	25	--	--	--	31	30	27	20	20	19	--	--	--
	4	5120	10842	18432	22	61	53	51	50	52	49	31	25	27	45	46	45	42	39	40	27	--	21	41	42	41	38	35	34	23	--	--
	6	7680	16264	27648	49	66	57	56	53	57	54	36	32	33	47	48	46	46	43	44	29	20	23	43	44	42	42	39	38	25	--	--
	8	10240	21685	36864	87	70	62	60	57	59	58	40	38	38	46	47	44	44	42	44	27	--	21	42	43	40	40	38	38	23	--	--
	10	12800	27106	46080	134	X	X	X	X	X	X	X	X	X	X	X	X	X	X	X	X	X	X	X	X	X	X	X	X	X	X	X
1800 x 900	2	3240	6861	11664	3	57	55	57	57	59	52	31	22	24	35	34	31	25	25	26	--	--	--	31	30	27	21	21	20	--	--	--
	4	6480	13722	23328	15	63	57	56	54	55	51	34	28	30	45	46	45	43	40	41	27	--	21	41	42	41	39	36	35	23	--	--
	6	9720	20584	34992	30	67	60	59	58	60	57	38	34	35	47	48	47	47	44	45	29	20	23	43	44	43	43	40	39	25	--	--
	8	12960	27445	46656	54	70	64	63	62	64	60	41	39	38	46	47	44	45	43	45	28	--	21	42	43	40	41	39	39	24	--	--
	10	16200	34306	58320	79	74	67	65	64	66	63	45	43	43	48	46	43	45	45	46	28	21	23	44	42	39	41	41	40	24	--	--
2000 x 1200	2	4800	10165	17280	5	58	54	55	54	56	49	30	22	24	35	34	32	27	27	27	--	--	--	31	30	28	23	23	21	--	--	--
	4	9600	20329	34560	22	63	55	53	51	53	49	33	28	30	45	46	46	45	42	43	28	--	22	41	42	42	41	38	37	24	--	--
	6	14400	30494	51840	49	68	60	58	56	58	55	38	35	35	47	48	47	48	45	47	30	22	24	43	44	43	44	41	41	26	--	20
	8	19200	40659	69120	87	72	64	62	59	61	59	42	40	40	46	47	45	47	44	46	29	20	23	42	43	41	43	40	40	24	--	--
	10	24000	50824	86400	134	X	X	X	X	X	X	X	X	X	X	X	X	X	X	X	X	X	X	X	X	X	X	X	X	X	X	X

1. Sound data is determined in a reverberation room at an independent sound laboratory, according to ISO 3741 and ISO 5135 standards.
2. L_w in dB/Oct. (re 1pW) are sound power levels for discharge sound and case radiated sound. Figures less than 17 dB are indicated by "--".
3. The discharge sound pressure levels are determined with the assumptions as referred to in table 1 for downstream ductwork including a diffuser with insulated plenum box.
4. The radiated sound pressure levels are determined with the assumptions as referred to in table 1 for ceiling plenum and suspended ceiling absorption.
5. Lp values are including a room absorption of 10 dB/Oct.
6. dB(A), NC and NR index figures are sound pressure levels. Figures less than 20 are indicated by "--".
7. Δps is static pressure drop across VAV air volume control terminal with damper fully open.
8. Sound data indicated by "X" are not provided as minimum required static pressure drop is more than the given pressure drop.
9. For non standard applications and/or selections, please contact our technical staff.

Table 1: Assumptions for additional attenuation

dB \ Hz	125	250	500	1000	2000	4000
Discharge (dB)	5	10	20	30	30	25
Radiated (dB)	2	5	10	15	15	20

Type NKOFOOB NKOFORB (single wall)
 NLOFOOB NLOFORB (double wall)

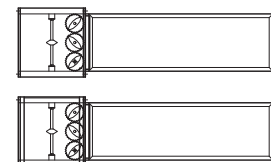

Sound data Δ p = 250 Pa

Model	inlet spigot				min. D p _s Pa	discharge sound						radiated sound single wall						radiated sound double wall														
	velocity		air volume			L _w in dB/Oct. (re 1pW)						Lp values			L _w in dB/Oct. (re 1pW)						Lp values											
						125 Hz	250 Hz	500 Hz	1000 Hz	2000 Hz	4000 Hz	dB(A)	NC	NR	125 Hz	250 Hz	500 Hz	1000 Hz	2000 Hz	4000 Hz	dB(A)	NC	NR	125 Hz	250 Hz	500 Hz	1000 Hz	2000 Hz	4000 Hz	dB(A)	NC	NR
	m/s	l/s	CFM	m ³ /h		dB									dB																	
350 x 200	2	140	296	504	9	48	41	37	31	32	39	18	--	--	31	30	24	-	-	-	--	--	--	27	26	20	-	-	-	--	--	--
	4	280	593	1008	39	58	50	43	35	33	37	28	22	24	42	42	38	30	27	27	21	--	--	38	38	34	26	23	21	--	--	--
	6	420	889	1512	78	63	55	48	40	38	41	33	28	30	43	44	39	33	30	31	23	--	--	39	40	35	29	26	25	--	--	--
	8	560	1186	2016	142	68	58	52	45	42	44	38	35	36	42	43	37	31	29	31	21	--	--	38	39	33	27	25	25	--	--	--
	10	700	1482	2520	225	72	62	55	49	46	47	42	41	41	44	43	36	31	31	33	22	--	--	40	39	32	27	27	27	--	--	--
400 x 400	2	320	678	1152	5	51	48	45	40	42	47	23	--	--	35	34	27	-	-	-	--	--	31	30	23	-	-	-	--	--	--	
	4	640	1355	2304	22	60	54	49	41	41	44	31	25	26	45	46	41	33	30	31	25	--	20	41	42	37	29	26	25	21	--	--
	6	960	2033	3456	48	65	58	53	45	45	48	36	31	32	47	48	43	37	34	35	27	20	23	43	44	39	33	30	29	23	--	--
	8	1280	2711	4608	85	69	63	56	48	47	51	40	37	37	46	47	40	35	33	35	25	--	21	42	43	36	31	29	29	21	--	--
	10	1600	3388	5760	132	72	65	58	51	50	53	43	41	41	48	46	39	35	35	36	25	--	21	44	42	35	31	31	30	21	--	--
500 x 400	2	400	847	1440	3	54	54	50	47	50	54	28	22	24	35	34	28	-	-	-	--	--	31	30	24	-	-	-	--	--	--	
	4	800	1694	2880	12	62	60	54	47	48	51	34	28	30	45	46	42	34	31	32	25	--	20	41	42	38	30	27	26	21	--	--
	6	1200	2541	4320	25	67	64	57	50	51	55	39	34	34	47	48	43	38	34	36	27	20	23	43	44	39	34	30	30	23	--	--
	8	1600	3388	5760	46	71	67	60	53	54	58	42	39	39	46	47	40	36	34	36	25	--	21	42	43	36	32	30	30	21	--	--
	10	2000	4235	7200	70	74	70	62	55	57	60	45	43	43	48	46	40	36	36	37	26	--	21	44	42	36	32	32	31	22	--	--
600 x 400	2	480	1016	1728	5	52	50	48	43	44	48	25	--	20	35	34	28	-	17	17	--	--	31	30	24	-	-	-	--	--	--	
	4	960	2033	3456	22	61	56	51	43	42	45	32	26	28	45	46	42	35	32	33	25	--	20	41	42	38	31	28	27	21	--	--
	6	1440	3049	5184	48	65	60	54	46	46	49	36	32	32	47	48	43	38	35	37	27	20	23	43	44	39	34	31	31	23	--	--
	8	1920	4066	6912	85	69	64	58	49	49	52	40	37	37	46	47	41	37	34	36	25	--	21	42	43	37	33	30	30	21	--	--
	10	2400	5082	8640	132	73	66	60	53	51	54	43	41	41	48	46	40	37	37	38	26	--	21	44	42	36	33	33	32	22	--	--
800 x 400	2	640	1355	2304	5	53	51	49	44	45	49	26	--	21	35	34	29	18	18	19	--	--	31	30	25	-	-	-	--	--	--	
	4	1280	2711	4608	22	61	57	52	44	43	46	33	26	28	45	46	42	36	33	34	25	--	20	41	42	38	32	29	28	21	--	--
	6	1920	4066	6912	48	66	61	55	48	47	50	37	33	34	47	48	44	40	37	38	27	20	23	43	44	40	36	33	32	23	--	--
	8	2560	5421	9216	85	70	64	59	51	50	53	41	38	38	46	47	41	38	36	38	26	--	21	42	43	37	34	32	32	22	--	--
	10	3200	6776	11520	132	74	67	61	54	52	55	44	43	42	48	46	40	38	38	39	26	--	21	44	42	36	34	34	33	22	--	--
900 x 450	2	810	1715	2916	4	55	55	53	48	50	52	29	22	25	35	34	29	19	19	20	--	--	31	30	25	-	-	-	--	--	--	
	4	1620	3431	5832	17	63	61	55	48	47	49	35	29	31	45	46	43	37	34	35	25	--	20	41	42	39	33	30	29	21	--	--
	6	2430	5146	8748	34	67	64	58	51	51	54	39	34	35	47	48	44	41	38	39	27	20	23	43	44	40	37	34	33	23	--	--
	8	3240	6861	11664	62	71	67	61	53	54	57	42	40	39	46	47	42	39	37	39	26	--	21	42	43	38	35	33	33	22	--	--
	10	4050	8576	14580	92	74	69	63	56	56	59	45	44	43	48	46	41	39	39	40	26	--	21	44	42	37	35	35	34	22	--	--

1. Sound data is determined in a reverberation room at an independent sound laboratory, according to ISO 3741 and ISO 5135 standards.
2. L_w in dB/Oct. (re 1pW) are sound power levels for discharge sound and case radiated sound. Figures less than 17 dB are indicated by "--".
3. The discharge sound pressure levels are determined with the assumptions as referred to in table 1 for downstream ductwork including a diffuser with insulated plenum box.
4. The radiated sound pressure levels are determined with the assumptions as referred to in table 1 for ceiling plenum and suspended ceiling absorption.
5. L_p values are including a room absorption of 10 dB/Oct.

6. dB(A), NC and NR index figures are sound pressure levels. Figures less than 20 are indicated by "--".
7. Δps is static pressure drop across VAV air volume control terminal with damper fully open.
8. Sound data indicated by "X" are not provided as minimum required static pressure drop is more than the given pressure drop.
9. For non standard applications and/or selections, please contact our technical staff.

Table 1: Assumptions for additional attenuation

dB \ Hz	125	250	500	1000	2000	4000
Discharge (dB)	5	10	20	30	30	25
Radiated (dB)	2	5	10	15	15	20

Sound data

Type NKOFOOB NKOFORB (single wall)
 NLOFOOB NLOFORB (double wall)

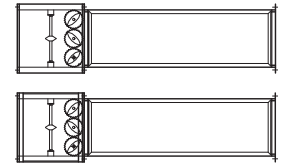

Sound data Δ p = 250 Pa

Model	inlet spigot				min. D p _s Pa	discharge sound									radiated sound single wall									radiated sound double wall											
	velocity		air volume			L _w in dB/Oct. (re 1pW)						Lp values			L _w in dB/Oct. (re 1pW)						Lp values			L _w in dB/Oct. (re 1pW)						Lp values					
						125 Hz	250 Hz	500 Hz	1000 Hz	2000 Hz	4000 Hz	dB(A)	NC	NR	125 Hz	250 Hz	500 Hz	1000 Hz	2000 Hz	4000 Hz	dB(A)	NC	NR	125 Hz	250 Hz	500 Hz	1000 Hz	2000 Hz	4000 Hz	dB(A)	NC	NR			
	m/s	l/s	CFM	m ³ /h		dB									dB									dB											
1000 x 500	2	1000	2118	3600	5	55	54	52	47	46	49	28	21	24	35	34	29	20	20	21	--	--	--	31	30	25	--	--	--	31	30	25	--	--	--
	4	2000	4235	7200	22	63	58	53	45	44	46	34	29	30	45	46	43	38	35	36	26	--	20	41	42	39	34	31	30	22	--	--	--		
	6	3000	6353	10800	48	67	63	57	50	48	51	38	34	35	47	48	45	42	38	40	28	20	23	43	44	41	38	34	34	24	--	--	--		
	8	4000	8471	14400	85	71	66	60	53	51	54	42	39	39	46	47	42	40	38	40	26	--	21	42	43	38	36	34	34	22	--	--	--		
	10	5000	10588	18000	132	74	68	62	56	54	57	45	43	43	48	46	41	40	40	41	26	--	21	44	42	37	36	36	35	22	--	--	--		
1200 x 600	2	1440	3049	5184	5	58	54	55	56	61	58	31	26	28	35	34	30	22	22	22	--	--	--	31	30	26	18	18	--	--	--	--			
	4	2880	6099	10368	22	65	58	56	54	57	55	36	32	32	45	46	44	40	37	37	26	--	20	41	42	40	36	33	31	22	--	--	--		
	6	4320	9148	15552	49	69	61	59	58	62	60	40	37	37	47	48	45	43	40	41	28	20	23	43	44	41	39	36	35	24	--	--	--		
	8	5760	12198	20736	87	73	64	62	60	64	63	43	42	41	46	47	43	41	39	41	26	--	21	42	43	39	37	35	35	22	--	--	--		
	10	7200	15247	25920	134	76	67	64	62	66	66	46	46	45	48	46	42	41	42	43	27	--	21	44	42	38	37	38	37	23	--	--	--		
1400 x 700	2	1960	4151	7056	3	62	59	62	63	66	61	36	28	31	35	34	31	23	23	24	--	--	--	31	30	27	19	19	18	--	--	--			
	4	3920	8301	14112	11	68	62	62	60	63	58	39	35	35	45	46	44	41	38	39	26	--	20	41	42	40	37	34	33	22	--	--	--		
	6	5880	12452	21168	26	72	66	65	64	67	63	43	40	40	47	48	46	45	41	43	29	20	23	43	44	42	41	37	37	24	--	--	--		
	8	7840	16602	28224	44	75	69	68	67	70	67	46	44	44	46	47	43	43	41	42	27	--	21	42	43	39	39	37	36	23	--	--	--		
	10	9800	20753	35280	69	77	71	69	69	72	69	48	48	46	48	46	42	43	43	44	27	--	21	44	42	38	39	39	38	23	--	--	--		
1600 x 800	2	2560	5421	9216	5	61	57	58	59	62	57	34	26	28	35	34	31	24	24	25	--	--	--	31	30	27	20	20	19	--	--	--			
	4	5120	10842	18432	22	67	60	58	56	59	55	38	34	35	45	46	45	42	39	40	27	--	21	41	42	41	38	35	34	23	--	--	--		
	6	7680	16264	27648	49	71	63	61	60	63	61	41	39	39	47	48	46	46	43	44	29	20	23	43	44	42	42	39	38	25	--	--	--		
	8	10240	21685	36864	87	74	66	64	63	66	64	45	43	43	46	47	44	44	42	44	27	--	21	42	43	40	40	38	38	23	--	--	--		
	10	12800	27106	46080	134	78	69	66	64	68	67	48	48	47	48	46	43	44	44	45	28	20	22	44	42	39	40	40	39	24	--	--	--		
1800 x 900	2	3240	6861	11664	3	64	62	64	64	65	59	38	30	32	35	34	31	25	25	26	--	--	--	31	30	27	21	21	20	--	--	--			
	4	6480	13722	23328	15	69	64	63	61	62	57	41	37	37	45	46	45	43	40	41	27	--	21	41	42	41	39	36	35	23	--	--	--		
	6	9720	20584	34992	30	73	67	66	65	67	63	44	41	41	47	48	47	47	44	45	29	20	23	43	44	43	43	40	39	25	--	--	--		
	8	12960	27445	46656	54	76	69	68	67	70	67	47	46	45	46	47	44	45	43	45	28	--	21	42	43	40	41	39	39	24	--	--	--		
	10	16200	34306	58320	79	78	71	70	69	72	70	49	49	47	48	46	43	45	45	46	28	21	23	44	42	39	41	41	40	24	--	--	--		
2000 x 1200	2	4800	10165	17280	5	65	61	61	61	63	56	37	31	32	35	34	32	27	27	27	--	--	--	31	30	28	23	23	21	--	--	--			
	4	9600	20329	34560	22	69	62	60	58	60	55	40	37	37	45	46	46	45	42	43	28	--	22	41	42	42	41	38	37	24	--	--	--		
	6	14400	30494	51840	49	73	65	63	62	65	61	43	41	41	47	48	47	48	45	47	30	22	24	43	44	43	44	41	41	26	--	--	20		
	8	19200	40659	69120	87	76	69	67	65	68	65	47	46	45	46	47	45	47	44	46	29	20	23	42	43	41	43	40	40	24	--	--	--		
	10	24000	50824	86400	134	79	71	69	67	70	68	50	48	48	46	44	47	47	47	48	29	23	25	44	42	40	43	43	42	25	--	--	21		

1. Sound data is determined in a reverberation room at an independent sound laboratory, according to ISO 3741 and ISO 5135 standards.
2. L_w in dB/Oct. (re 1pW) are sound power levels for discharge sound and case radiated sound. Figures less than 17 dB are indicated by "--".
3. The discharge sound pressure levels are determined with the assumptions as referred to in table 1 for downstream ductwork including a diffuser with insulated plenum box.
4. The radiated sound pressure levels are determined with the assumptions as referred to in table 1 for ceiling plenum and suspended ceiling absorption.
5. Lp values are including a room absorption of 10 dB/Oct.

6. dB(A), NC and NR index figures are sound pressure levels. Figures less than 20 are indicated by "--".
7. Δps is static pressure drop across VAV air volume control terminal with damper fully open.
8. Sound data indicated by "X" are not provided as minimum required static pressure drop is more than the given pressure drop.
9. For non standard applications and/or selections, please contact our technical staff.

Table 1: Assumptions for additional attenuation

dB \ Hz	125	250	500	1000	2000	4000
Discharge (dB)	5	10	20	30	30	25
Radiated (dB)	2	5	10	15	15	20



OUR TECHNOLOGY | YOUR WELLBEING

BARCOL-AIR | AIR DISTRIBUTION

Cantekoogweg 10-12 - 1442 LG Purmerend, The Netherlands

T +31 (0)299 689 300 | **E** export@barcol-air.nl

WWW.BARCOL-AIR.NL